

SUCSPA & SUCSHA

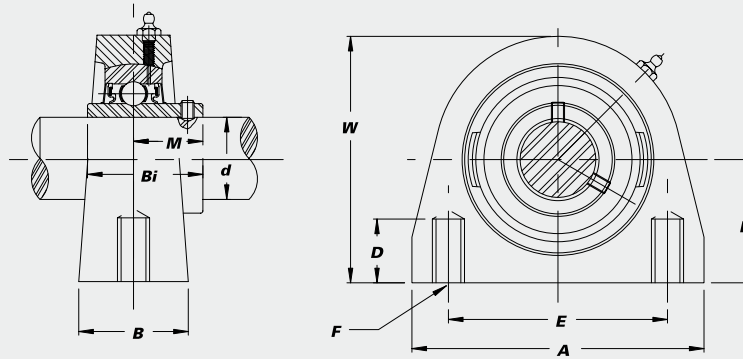

SUCSPA Tapped Base Units All Stainless Steel

• B-type seals



Unit No.	Shaft Dia. <i>d</i>		Dimensions (in.) (mm)								Bearing No.	Housing No.	Weight (lbs.)	
	(in.)	(mm)	<i>H</i>	<i>A</i>	<i>E</i>	<i>B</i>	<i>W</i>	<i>F</i> -Tapped Holes	<i>D</i> -Min Tap Depth	<i>M</i>				<i>Bi</i>
SUCSPA 201-8	1/2	12.7	1 1/16	2 7/8	2	1 1/2	2 9/16	3/8"-16	1/2	0.7205	1.2205	SUC 201-8	SPA 204	1.5
SUCSPA 202-10	5/8	15.9	33.3	73	50.8	38	65	UNC	13	18.3	31.0	SUC 202-10		
SUCSPA 204-12	3/4	19.0	1 5/16	2 7/8	2	1 1/2	2 9/16	3/8"-16	1/2	0.7205	1.2205	SUC 204-12	SPA 204	1.4
SUCSPA 204-12	20	33.3	73	50.8	38	65	UNC	13	18.3	31.0				
SUCSPA 205-14	7/8	22.1	1 7/16	3	2	1 1/2	2 13/16	3/8"-16	1/2	0.7756	1.3386	SUC 205-14	SPA 205	1.8
SUCSPA 205	25	36.5	76	50.8	38	71	UNC	13	19.7	34.0	SUC 205-16			
SUCSPA 205-16	1	25.4	36.5	76	50.8	38	71	UNC	13	19.7	34.0	SUC 205-16		
SUCSPA 206-18	1 1/8	31.8	1 11/16	4	3	1 1/2	3 3/8	7/16"-14	5/8	0.8740	1.5000	SUC 206-18	SPA 206	2.9
SUCSPA 206	30	42.9	102	76.2	38	86	UNC	16	22.2	38.1	SUC 206-19			
SUCSPA 206-19	1 3/16	38.1	102	76.2	38	86	UNC	16	22.2	38.1	SUC 206-20			
SUCSPA 206-20	1 1/4	31.8	42.9	102	76.2	38	86	UNC	16	22.2	38.1	SUC 206-20		
SUCSPA 207-20	1 1/4	31.8	1 7/8	4 1/4	3 1/4	1 7/8	3 3/4	1/2"-13	3/4	1.0000	1.6890	SUC 207-20	SPA 207	3.8
SUCSPA 207-21	1 5/16	39.7	47.6	108	82.6	48	95	UNC	19	25.4	42.9	SUC 207-21		
SUCSPA 207-22	1 3/8	34.9	47.6	108	82.6	48	95	UNC	19	25.4	42.9	SUC 207-22		
SUCSPA 207	35	47.6	108	82.6	48	95	UNC	19	25.4	42.9	SUC 207			
SUCSPA 207-23	1 7/16	39.7	47.6	108	82.6	48	95	UNC	19	25.4	42.9	SUC 207-23		

SUCSHA Hanger Units All Stainless Steel

• B-type seals

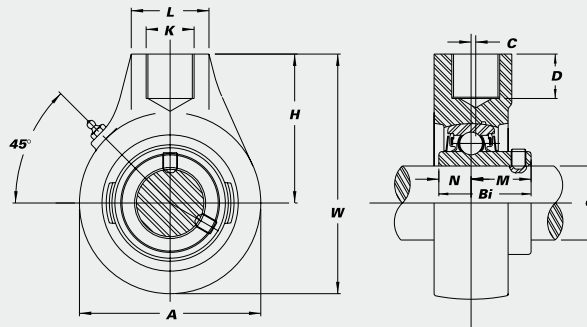

Unit No.	Shaft Dia. <i>d</i>		Dimensions (in.) (mm)									Bearing No.	Housing No.	Weight (lbs.)	
	(in.)	(mm)	<i>A</i>	<i>W</i>	<i>C</i>	<i>H</i>	<i>L</i>	<i>D</i>	<i>K</i>	<i>Bi</i>	<i>N</i>				<i>M</i>
SUCSHA 205-14	7/8	22.1	2 3/4	3 29/32	0	2 33/64	1 9/16	3/4	PF 3/4	1.3386	0.5630	0.7756	SUC 205-14	SHA 205	1.6
SUCSHA 205	25	70	99	0	64	40	19.1	-14	34.0	14.3	19.7	SUC 205-16			
SUCSHA 205-16	1	25.4	70	99	0	64	40	19.1	-14	34.0	14.3	19.7	SUC 205-16		
SUCSHA 206-18	1 1/8	31.8	3 5/32	4 3/32	0	2 33/64	1 9/16	3/4	PF 3/4	1.5000	0.6260	0.8740	SUC 206-18	SHA 206	1.9
SUCSHA 206	30	80	104	0	64	40	19.1	-14	38.1	15.9	22.2	SUC 206-19			
SUCSHA 206-19	1 3/16	38.1	104	0	64	40	19.1	-14	38.1	15.9	22.2	SUC 206-20			
SUCSHA 206-20	1 1/4	31.8	80	104	0	64	40	19.1	-14	38.1	15.9	22.2	SUC 206-20		
SUCSHA 207-20	1 1/4	31.8	3 5/8	4 9/16	0	2 3/4	1 9/16	3/4	PF 3/4	1.6890	0.6890	1.0000	SUC 207-20	SHA 207	2.6
SUCSHA 207-21	1 5/16	39.7	92	116	0	70	40	19.1	-14	42.9	17.5	25.4	SUC 207-21		
SUCSHA 207-22	1 3/8	34.9	92	116	0	70	40	19.1	-14	42.9	17.5	25.4	SUC 207-22		
SUCSHA 207	35	92	116	0	70	40	19.1	-14	42.9	17.5	25.4	SUC 207			
SUCSHA 207-23	1 7/16	39.7	92	116	0	70	40	19.1	-14	42.9	17.5	25.4	SUC 207-23		

CORROSION RESISTANT