

SBRFB & SARFB 3-Bolt Flange Units

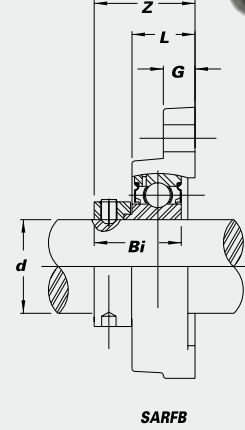

- Ductile iron housing
- Narrow inner race bearing
- K-type seals

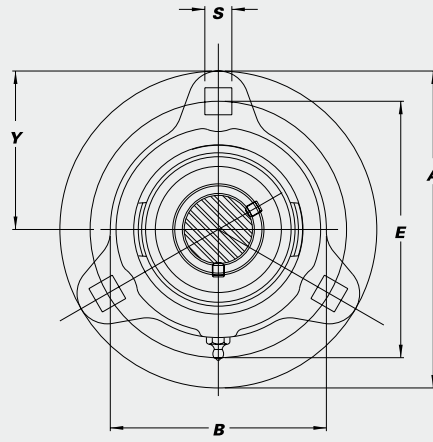
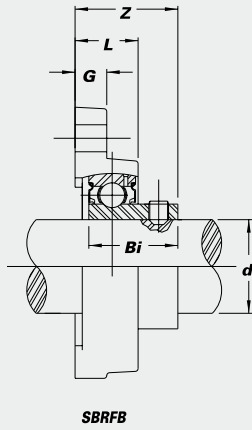

SBRFB Set screw type

Unit No.	Shaft Dia.		Dimensions (in.) (mm)									Bolt Used (in)	Bearing No.	Housing No.	Weight (lbs.)
	d (in.)	d (mm)	A	E	G	B	L	S	Z	Bi	Y				
SBRFB 204-12 204	3/4	20	3 ⁹ / ₁₆	2 ¹³ / ₁₆	7 ¹ / ₁₆	2 ⁵ / ₈	2 ⁵ / ₃₂	1 ¹¹ / ₃₂	1 ⁵ / ₃₂	0.9843	1 ²⁵ / ₃₂	5/16	SB 204-12G 204G	RFB 204	.8
SBRFB 205-14 205	7/8	25	3 ³ / ₄	3	7 ¹ / ₁₆	2 ⁷ / ₈	2 ⁵ / ₃₂	1 ¹¹ / ₃₂	1 ⁷ / ₃₂	1.0630	1 ⁷ / ₈	5/16	SB 205-14G 205G	RFB 205	.9
SBRFB 205-15 205-16	1 ⁵ / ₁₆	1	95	76.2	11	73	20	9	31.0	27.0	48	5/16	SB 205-15G 205-16G	RFB 205	.9
SBRFB 206-17 206-18 206	1 ¹ / ₁₆ 1 ¹ / ₈	30	4 ⁷ / ₁₆	3 ⁹ / ₁₆	1 ⁵ / ₃₂	3	5 ⁷ / ₆₄	1 ³ / ₃₂	1 ⁵ / ₁₆	1.1811	2 ⁷ / ₃₂	3/8	SB 206-17G 206-18G 206G	RFB 206	1.2
SBRFB 206-19 206-20	1 ³ / ₁₆ 1 ¹ / ₄ S		113	90.5	12	76	23	10	33.3	30.0	56	3/8	SB 206-19G 206-20G	RFB 206	1.2
SBRFB 207-20 207-21 207-22 207	1 ¹ / ₄ 1 ⁵ / ₁₆ 1 ³ / ₈	35	4 ¹³ / ₁₆	3 ¹⁵ / ₁₆	1/2	3 ¹ / ₂	1 ⁵ / ₁₆	1 ³ / ₃₂	1 ⁷ / ₁₆	1.2992	2 ¹³ / ₃₂	3/8	SB 207-20G 207-21G 207-22G 207G	RFB 207	1.7
SBRFB 207-23	1 ⁷ / ₁₆											3/8	SB 207-23G	RFB 207	1.7

SARFB Eccentric locking collar type

Unit No.	Shaft Dia.		Dimensions (in.) (mm)									Bolt Used (in)	Bearing No.	Housing No.	Weight (lbs.)
	d (in.)	d (mm)	A	E	G	B	L	S	Z	Bi	Y				
SARFB 204-12 204	3/4	20	3 ⁹ / ₁₆	2 ¹³ / ₁₆	7 ¹ / ₁₆	2 ⁵ / ₈	2 ⁵ / ₃₂	1 ¹¹ / ₃₂	1 ⁵ / ₁₆	1.2205	1 ²⁵ / ₃₂	5/16	SA 204-12G 204G	RFB 204	.9
SARFB 205-14 205	7/8	25	3 ³ / ₄	3	7 ¹ / ₁₆	2 ⁷ / ₈	2 ⁵ / ₃₂	1 ¹¹ / ₃₂	1 ³ / ₈	1.2205	1 ⁷ / ₈	5/16	SA 205-14G 205G	RFB 205	1.0
SARFB 205-15 205-16	1 ⁵ / ₁₆	1	95	76.2	11	73	20	9	34.9	31.0	48	5/16	SA 205-15G 205-16G	RFB 205	1.0
SARFB 206-17 206-18 206	1 ¹ / ₁₆ 1 ¹ / ₈	30	4 ⁷ / ₁₆	3 ⁹ / ₁₆	1 ⁵ / ₃₂	3	5 ⁷ / ₆₄	1 ³ / ₃₂	1 ¹¹ / ₃₂	1.4055	2 ⁷ / ₃₂	3/8	SA 206-17G 206-18G 206G	RFB 206	1.3
SARFB 206-19 206-20	1 ³ / ₁₆ 1 ¹ / ₄ S		113	90.5	12	76	23	10	38.9	35.7	56	3/8	SA 206-19G 206-20G	RFB 206	1.3
SARFB 207-20 207-21 207-22 207	1 ¹ / ₄ 1 ⁵ / ₁₆ 1 ³ / ₈	35	4 ¹³ / ₁₆	3 ¹⁵ / ₁₆	1/2	3 ¹ / ₂	1 ⁵ / ₁₆	1 ³ / ₃₂	1 ²¹ / ₃₂	1.5315	2 ¹³ / ₃₂	3/8	SA 207-20G 207-21G 207-22G 207G	RFB 207	2.0
SARFB 207-23	1 ⁷ / ₁₆											3/8	SA 207-23G	RFB 207	2.0

Interchange Page 91

STANDARD PRODUCTS